



**DOVER SUPPLY PTE LTD**  
"The Instruments & Materials Supply Centre"

Since 1981

63 UBI CRESCENT, Singapore 408 599  
T. +65 6294 6866 F. +65 6294 0635

www.doversupply.com.sg  
sales@doversupply.com.sg

# ENGINE INSTRUMENTS — LEUTERT SERIES

## (Engine peak indicators – MSI-3)

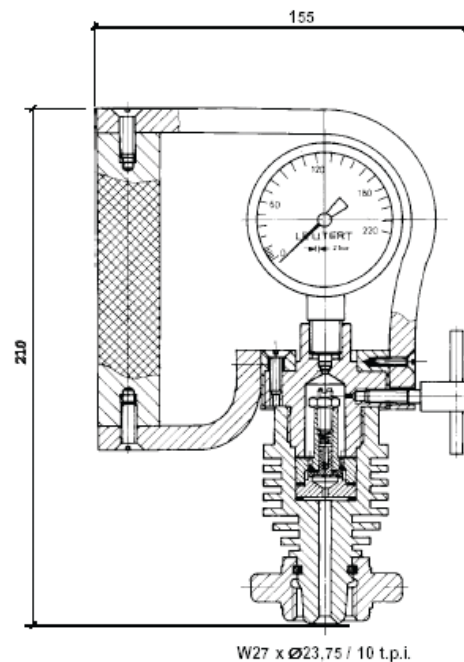

Measuring Range:	0-160 Bar or 0-220 Bar or 0-250 Bar
Error:	+/- 1.6%
Engine Sizes:	Up to n=2,500 r.p.m
Dimension:	Approx. 210 x 155 x 60mm
Features:	Easy handling High accuracy in all speed ranges Extremely robust and little maintenance Insensitive to vibration Steel-manometer in safety construction
Application:	<b>LEUTERT</b> peak pressure indicator MSI 3 serves for indicating the maximum value of rapidly varying gas pressures. The instrument is particularly suited for indicating diesel engines.
Standard Accessories:	1 wooden case 1 spanner for connecting nut 1 pad measuring log 1 instruction manual
Weight:	2.1 kg (without wooden case) 3.6 kg (with wooden case)